

INSTRUCTION MANUAL FOR SELF-LEARNING MODEL RMC-600 & Y2K10L



RMC-600



Y2K10L

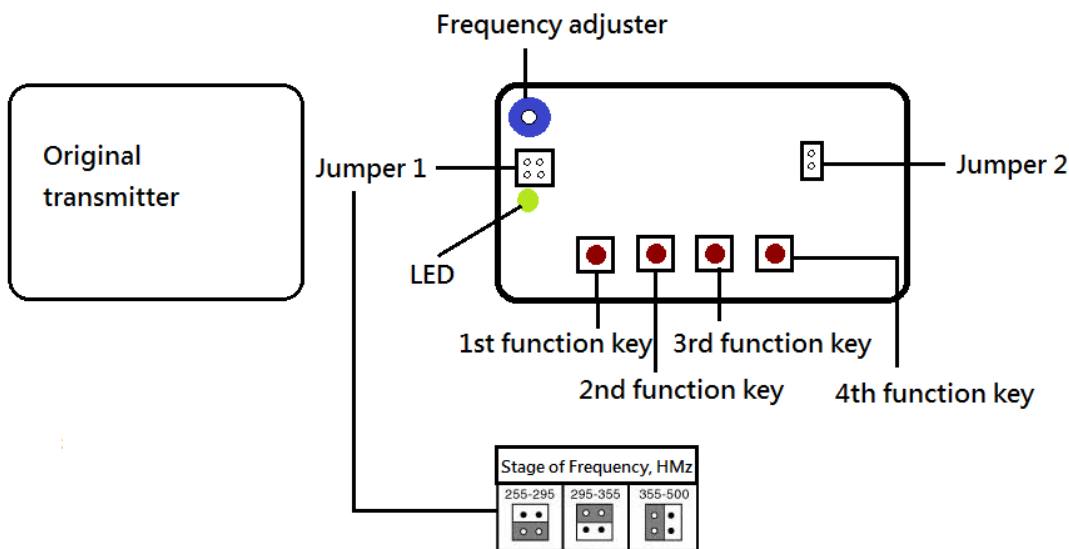

Note: If the existing remote is code hopping you will not be able to clone it successfully.

- 1). Setting the frequency (Using our adjusted bar).
 - a. Make sure jumper 2 is installed and place 2 remotes(existing remote and REMOCOL remote) within 1 cm of each other. Press any button of both remotes and hold until the LED of REMOCOL remote flashes 3 times.
 - b. Still hold the buttons and increase the distance of both remotes to about 3 cm apart and observe the brightness of LED of REMOCOL remote. Adjust the frequency until the LED show maximum brightness.
 - c. If you can't find a suitable adjustment, change the jumper 1 to the next position and repeat from step a.

** If you have a frequency counter, you can remove jumper 2 and then adjust the frequency by frequency counter as well. Be sure to set back jumper for next procedure.

- 2). Place the two remotes within 2 cm of each other. Press and hold the button of existing remote that you want to copy from and press and hold the button of REMOCON remote that you want to copy to and wait until the LED of Remocon remote flashes 3 times. Repeat above step for the rest buttons you wish to copy.
- 3). When you finish it, remove jumper 2 and place it in a way that only one leg is connected. (This can prevent from losing your jumper next time you want to program the remote.)
- 4). Please make sure only to program remotes in areas far from electrical interference. Otherwise, the remote may program incorrectly.

P.S. If you did not know the existing remote is hopping or not, suggest to do step 2 first. Just need to test one button of it and see whether LED of REMOCON remote flash 3 times. Do this to make sure that existing remote is OK to be copied. The procedures must be done in order from step 1 to step 3.